

OPERATING PRINCIPLE

Esprecious



All rights reserved.

No part of this document may be copied and/or published by means of printing, photocopying, microfilming or by any other means whatsoever without the prior written consent of the manufacturer. This also applies to the included drawings and/or diagrams.

The information in this document is based on data that was available at the time the design, the material characteristics and the operating methods were published, meaning that this document is subject to change. For this reason, the instructions are merely a guideline for the installation, maintenance and repair of the machine displayed on the front cover.

This document applies to the standard version of this machine.

The manufacturer therefore declines all liability for any damage arising from specifications that deviate from the standard version of the machine delivered to you.

This document has been compiled with the utmost care. However, the manufacturer cannot be held liable for any errors it contains or the consequences thereof.

Table of Contents

1. General operation	.1
2. Water dosing system	.2
2.1 Water dosing system for hot water or instant product	.2
2.2 Water dosing system for coffee product	.2
3. Starting up the machine	.4
3.1 Initialization	.4
3.2 Installation	.4
3.3 Filling the machine	.4
3.4 Boiling point determination program	.5
3.5 Heating	.5
3.6 Dosing hot water or instant product	.6
3.7 Dosing the coffee product	.9
4. Powder dosing system	.11
5. Mixing system	.12
6. Ventilation system	.13
7. Brewer	.14
7.1 Brewer operation	.14
7.2 Brewer heating	.15
8. Coffee grinder	.16
8.1 Calibration	.16
9. Recipes	.17
9.1 Recipe settings	.17
10. Operating system	.18
10.1 Touch screen including control board	.18
10.2 Control board	.18
10.3 Bus system	.18
11. Hardware protection	.19
11.1 Overflow protection	.19
11.2 Return flow protection	.19
11.3 High temperature safety switch	.19
11.4 Waste bin (brewer) protection	.19
11.5 Grinder protection	.19
12. Software protection	.20
13. The Esprecious program	.22

Table of Figures

Fig.1	Water dosing system2
Fig.2	Float tank complete3
Fig.3	Boiler complete3
Fig.4	Water selector complete3
Fig.5	Boiling point determination program5
Fig.6	Pump motor + rotor6
Fig.7	Pump housing6
Fig.8	Encoder7
Fig.9	Water selector7
Fig.10	Water selector internal7
Fig.11	Water rotation disc7
Fig.12	Water rotation disc8
Fig.13	Water rotation disc with wide shaft8
Fig.14	Water selector components8
Fig.15	Flow meter9
Fig.16	Rotation pump9
Fig.17	Manometer9
Fig.18	Boiler incl. heat exchanger9
Fig.19	Valve10
Fig.20	Brewer10
Fig.21	Mixing unit12
Fig.22	Exhaust hood12
Fig.23	Steam exhaust system for the mixing system12
Fig.24	Ventilation system13
Fig.25	Brewer with a housing in a position that enables coffee to be dosed14
Fig.26	Brewer with coffee cake that is being pressed so water can be dosed14
Fig.27	Brewer with retracted housing15
Fig.28	Brewer with entirely retracted housing so the coffee cake falls in the waste bin15
Fig.29	Dual grinder16
Fig.30	Recipe screen17
Fig.31	Info screen17
Fig.32	Bus system diagram18
Fig.33	Drip tray for the water selector19
Fig.34	Programming map23

1. General operation

The machine works according to two different dosing systems:

1. a low pressure pump system developed by Bravilor Bonamat;
2. a high pressure pump system including pressure meter.

Both systems have the following advantages:

- Many of the parts that ensure that the water is dosed properly are in the cold water circuit. This reduces the main cause of failures, namely the formation of limescale on the dosing valves, to a minimum.
- The float that regulates the water level is also in the cold water circuit. This also reduces scaling to a minimum.

2. Water dosing system

2.1 Water dosing system for hot water or instant product

Selecting a drink triggers the (low pressure) pump motor, which has a controlled time and speed. The pump rotor moves a certain amount of cold water from the cold water reservoir to the bottom of the boiler. This pushes the hot water in the boiler upwards towards the water selector. This selector selects its position by means of a rotating movement (drink-dependent). Depending on the selected drink, an ingredient is dosed and mixed in the mixing chamber with the dosed water before flowing into the cup.

2.2 Water dosing system for coffee product

Selecting a drink triggers the high pressure pump and opens the valve on the boiler. The flow meter determines the amount of water that is moved. The water passes through the flow meter to the heat exchanger (in the boiler) to the brewer. When the predefined amount of water has been reached, the high pressure pump switches off and the valve closes. The amount of coffee that is ground is based on the amount of coffee that is set for the selected drink. The ground coffee in the brewer is pressed creating a coffee cake through which the water is pressed at a specific pressure so it can flow into the cup.

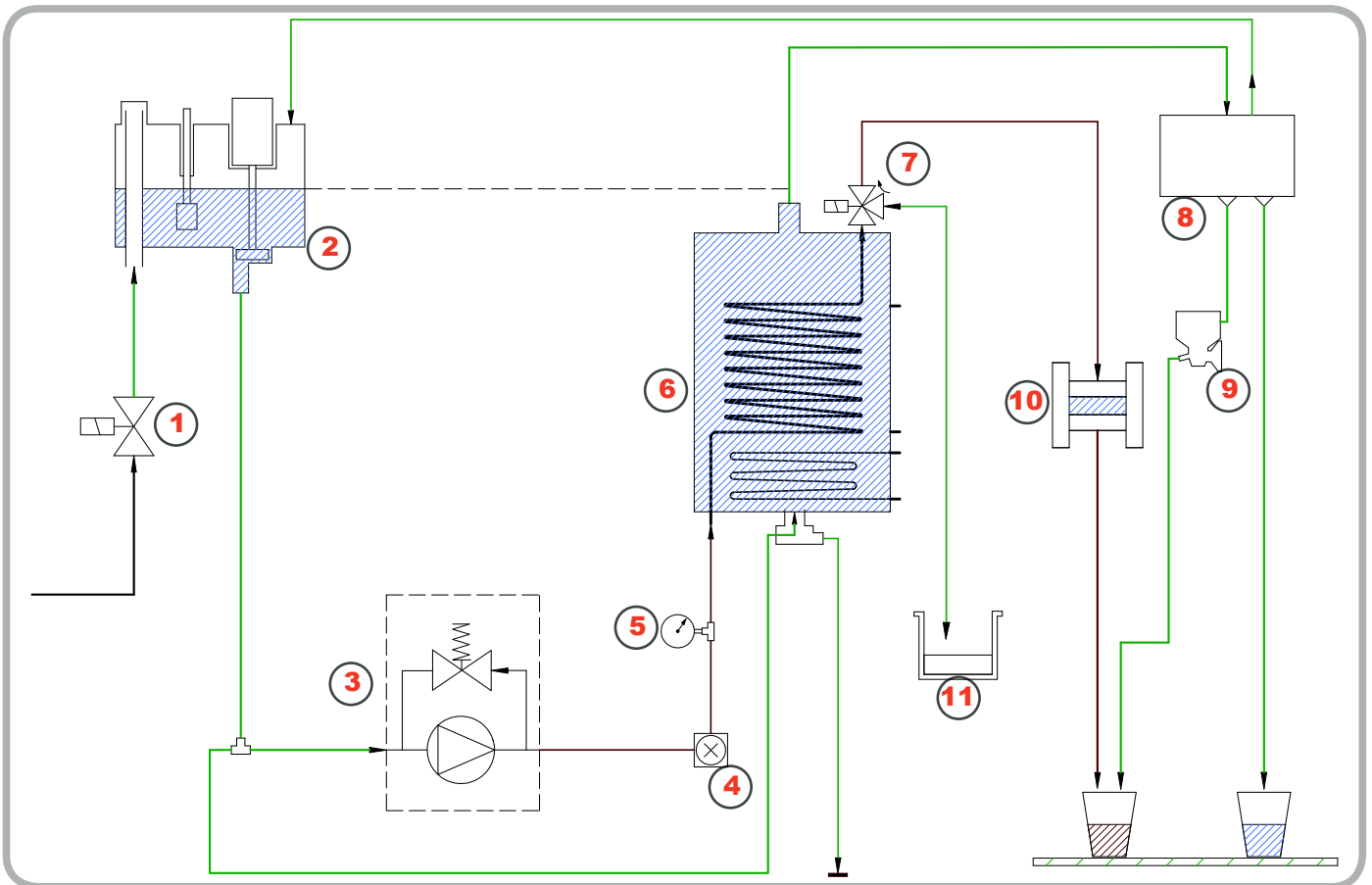

Fig.1 Water dosing system

The water dosing system consists of the following main components:

1. Magnetic valve
2. Float tank complete (Fig.2)
 - 2a. Float
 - 2b. Pump motor
 - 2c. Pump rotor
 - 2d. Pump housing
 - 2e. Encoder
3. High pressure pump (rotation)
4. Flow meter
5. Manometer
6. Boiler (complete) (Fig.3)
 - 6a. Element
 - 6b. Heat exchanger
 - 6c. Temperature sensor
 - 6d. Temperature sensor
7. Electric valve
8. Water selector complete (Fig.4)
 - 8a. Water selector motor
 - 8b. Top cover of water selector
 - 8c. Light sensor
 - 8d. Water rotation disc
 - 8e. Water distributor
9. Mixing chamber (for instant products)
10. Brewer
11. Waste bin

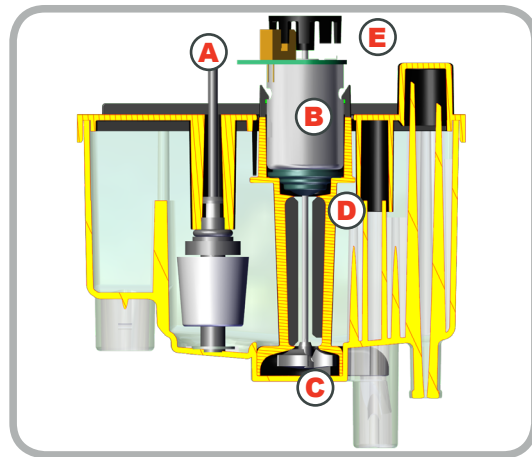

Fig.2 Float tank complete

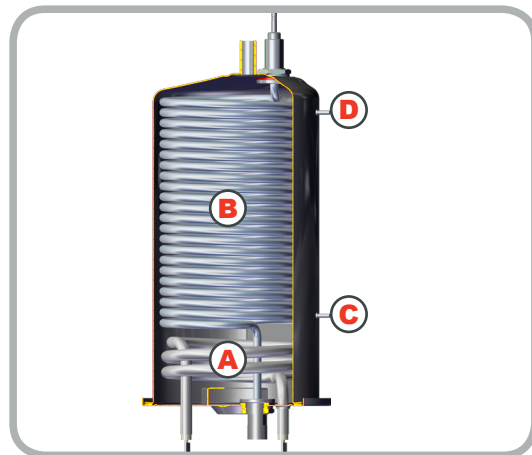

Fig.3 Boiler complete

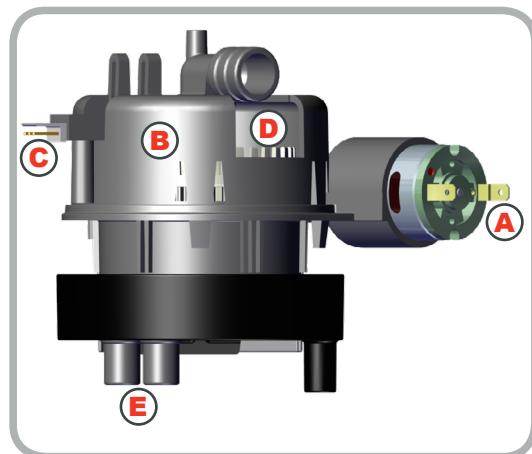

Fig.4 Water selector complete

3. Starting up the machine

3.1 Initialization

The machine is switched on by activating the main switch.

The touch screen displays the Bravilor Bonamat logo, the date; of the GUI (Graphical User Interface) and the version of the GUI.

The machine is operational in about 30 seconds and the touch screen displays the acceptance screen stating that the safety booklet must be read.

The installation can start once the safety booklet has been read and the message accepted.

3.2 Installation

The installation menu displays a number of basic settings that are selected by default and that you must always go through.

You can also select additional settings that will be displayed during the installation procedure. Once the settings have been selected and confirmed, and you have confirmed that the temperature can be calibrated, the machine will start to fill up with water.

All of the information needed during installation is displayed on the touch screen. Additional information about the different parts is available by pressing on the  icon in the top left of the screen.

During installation, the boiling point determination program (see 3.4) will run and you can continue with the installation until the water needs to be dosed.

Note:

- ▶ *All of the settings can be changed after installation.*

3.3 Filling the machine

The float tank and the boiler are connected by a siphon hose.

Together they create a communication entity.

When the machine is switched on for the first time, the float tank (Fig.2) is empty and the float (Fig.2, A) in a lowered position.

- The magnetic valve (Fig.1) opens and fills the float tank with water at a pressure-independent speed of 2 litres/minute.
- The water in the float tank runs through the hose under the float tank to the boiler.
- When the water has reached a level that pushes the float upward, the water level in the float tank is equal to that in the boiler.

The magnetic valve switches off.

Note:

- ▶ *Because the float tank fills faster than the water 'drops' into the boiler, the filling process will take place with short intervals.*

3.4 Boiling point determination program

Hot water may come out of the hot water outlet while this program is running.

The machine automatically runs through the boiling point determination program the first time the machine is used. The boiling point of the water is now determined. This is necessary because the boiling point depends on the local atmospheric pressure. The boiling point at sea level will be about 100°C, while the boiling point at 2,000 m is somewhat lower at 97°C. The water in the boiler is heated at full power to about 80°C when the machine is switched on (Fig.5, A).

The water is then heated in the boiler at reduced power until the temperature sensor on the outside of the boiler stops registering a change in temperature for a few minutes (Fig.5, B). The boiling point has been reached and the measured value is saved in the software. The operational temperature in the boiler will be 8°C below this point. Because the boiling point of water depends on the atmospheric pressure, this program must run at the location where the machine will be used. The actual temperature is displayed during the boiling program. The boiling point determination program takes about 20 minutes to determine the boiling point.

Note:

- ▶ *When the boiling point determination program has finished, the temperature in the boiler is around boiling point and about 1 litre of water will be drained through the coffee outlet to gradually reduce the temperature in the boiler and prepare the machine for use.*

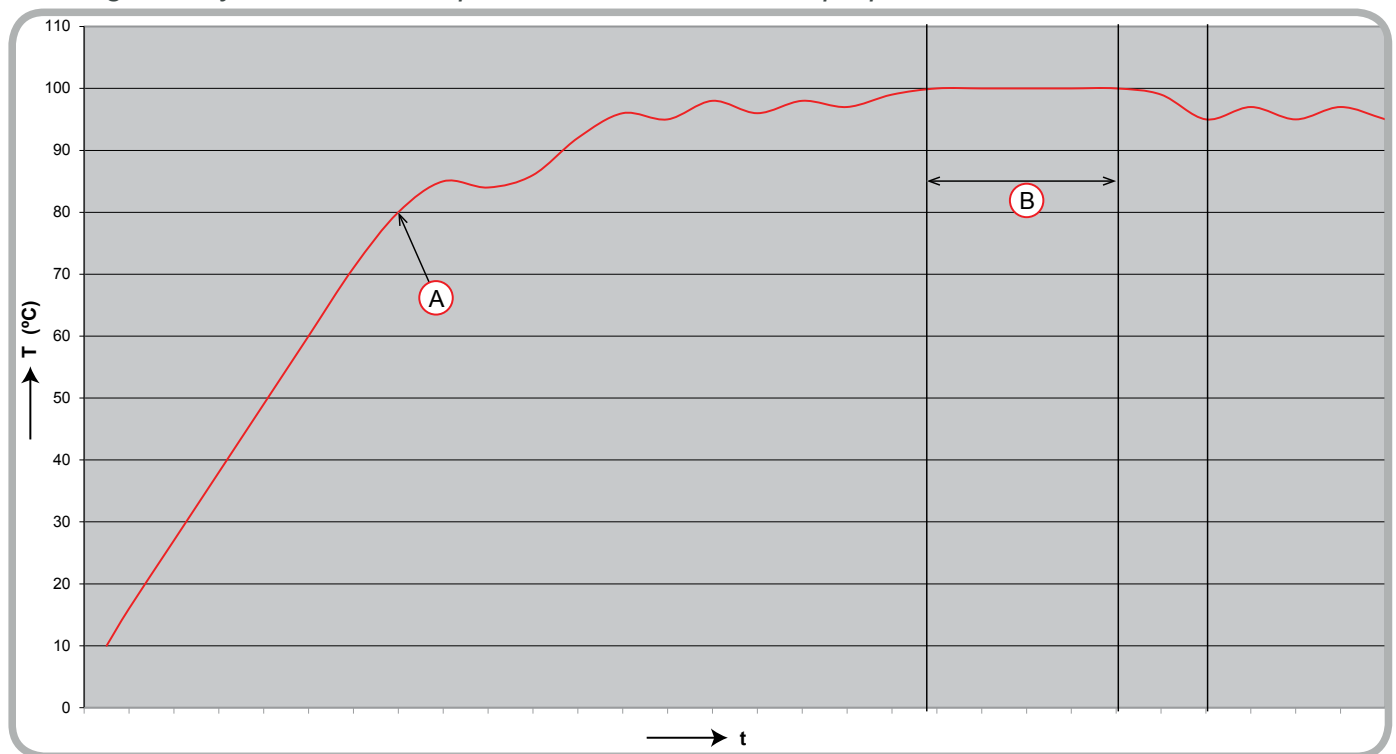

Fig.5 Boiling point determination program

3.5 Heating

Now that the system has been filled with water (Fig.3, A), a relay on the control board will switch on the element. The low temperature sensor (Fig.3, C), which is on the outside of the boiler, measures the actual temperature of the water. The temperature sensor ensures that the water in the boiler is heated to the de-sired temperature.

When the installation has finished, the actual temperature is displayed on the touch screen. This indicates that the machine is not yet ready for use. The temperature sensor is an NTC (Negative Temperature Coefficient) thermistor. The higher the measured temperature, the lower the sensor's resistance. Hot water has a lower specific weight than cold water. As a result, the hot water in the boiler will not flow back to the float tank through the siphon hose at the bottom. That part of the system will therefore remain cold. This is very important because the parts in the float tank are sensitive to limescale. The temperature sensor is on the outside of the boiler. As a result, there is no feed-through in the wall meaning that the system will not leak over time. This measurement is less direct. That is why the temperature is regulated proportionally.

The heating switches on for a specific amount of time and off for a specific amount of time. A measurement is made after the period that the heating has been off. The heating will be on for a longer or shorter period depending on the measurement. The higher the temperature in the boiler, the shorter the moments become that the element is on, and the longer the intermediate time becomes. This enables an accurate temperature to be obtained in the boiler.

There is a second temperature sensor on the boiler (Fig.3, D). This sensor monitors the outlet temperature of the dosed water. If this sensor measures a too low temperature, the machine is blocked. No more water is dosed.

3.6 Dosing hot water or instant product

Hot water or instant product is dosed when:

- The float is in the highest position.
- The high temperature sensor measures a temperature that is higher than the blocking temperature.
- Pressing a selection button starts the pump motor (Fig.6) for a given period of time at a certain speed (rpm) based on the programmed amount.

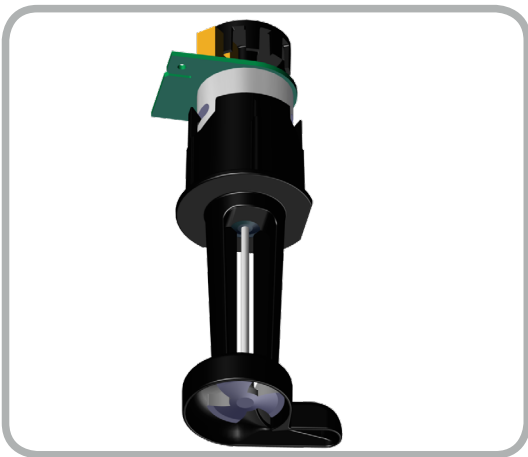

Fig.6 Pump motor + rotor

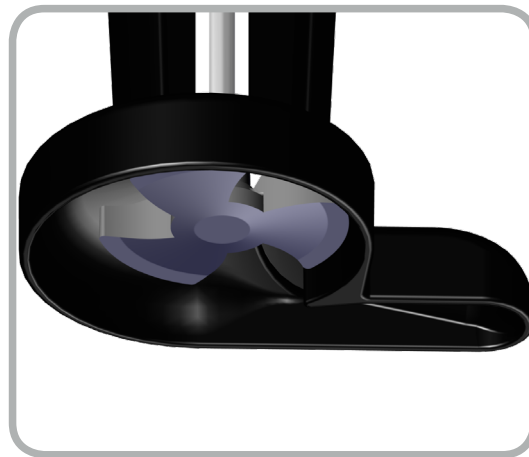

Fig.7 Pump housing

- The pump rotor rotates in the water-filled pump chamber. It is shaped by the bottom of the float tank and the bottom of the pump housing (Fig.7).
- The pump rotor pumps the water from the pump chamber through the siphon hose at the bottom of the boiler.
- This presses the hot water out of the boiler.
- The float and the magnetic valve ensure that the correct level of water is maintained in the float tank and in the pump chamber.

The volume of moved liquid (yield) is mainly determined by the time and speed of the pump motor. The time that the motor is on is controlled by the software and is very accurate. The motor's number of revolutions is measured with an active revolution counter. Fig.8 shows that a disc is mounted on the shaft of the pump motor (A = Encoder). This disc rotates at the same speed as the pump rotor. The encoder rotates between a light sensor (B) interrupting the light beam each time. The interruption of the light beam is converted into pulses that can be read by the electronics.

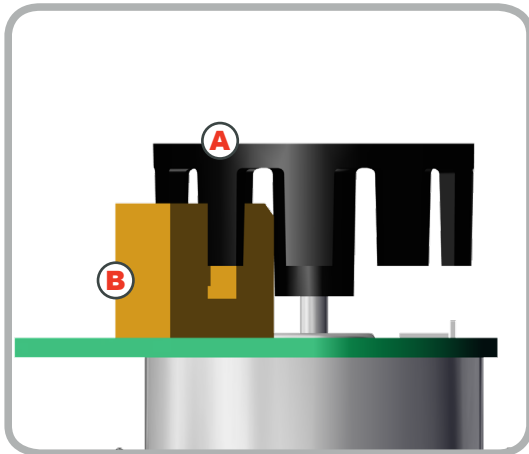

Fig.8 Encoder

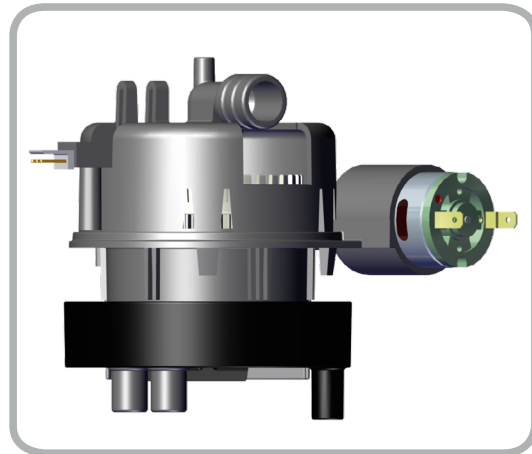

Fig.9 Water selector

This active control of the rotational speed guarantees that the number of revolutions per minute and therefore the water yield remain constant while the pump motor is on.

Selecting the dosed hot water:

- This machine has a hot water selector.
- This component (Fig.9) enables the dosed water in the boiler to be dosed in two directions: the hot water outlet or the mixing chamber (instant product).

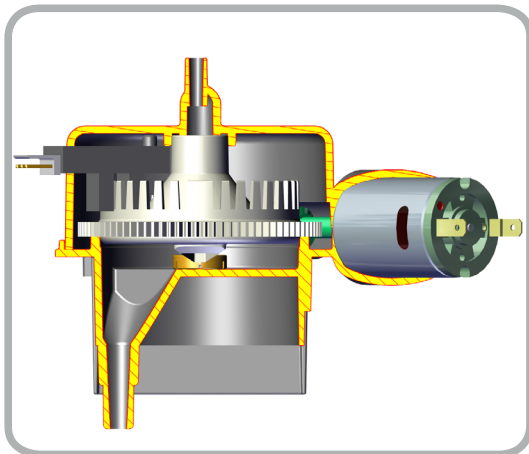

Fig.10 Water selector internal

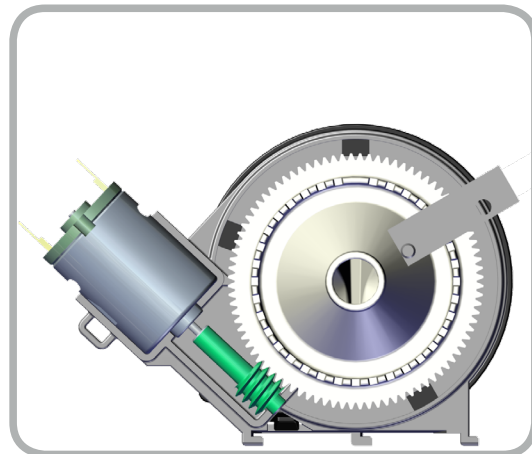

Fig.11 Water rotation disc

After the machine has been switched on, the water selector goes into stand-by according to the following procedure:

- The water selector motor is triggered.
- This motor drives the water rotation disc with a plastic worm (Fig.10/Fig.11).
- The shafts on the rotation disc interrupt the light beam emitted by the light sensor and transmit the pulses to the controls (Fig.12).
- The start position is determined when the light sensor detects the wide shaft on the rotation disc (Fig.12/Fig.13).

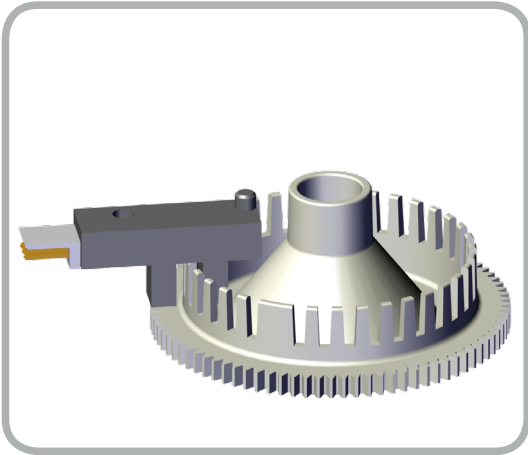

Fig. 12 Water rotation disc

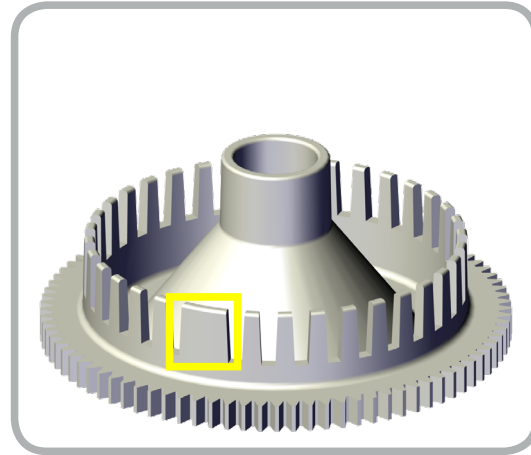

Fig. 13 Water rotation disc with wide shaft

Operation of the water selector after a selection button has been pressed:

- The water selector determines its position based on the selected drink.
- Once the position has been determined, the pump motor is triggered.
- The dosed hot water is pumped into the top of the water selector (Fig. 14A).
- The water flows through the centre hole in the rotation disc (Fig. 14B). The water exits through the oblique hole at the bottom (Fig. 14C).
- The water then drops into one of the chambers at the bottom of the water selector (Fig. 14D).
- The water flows through the connected hoses to the appropriate component.
- The water selector returns to the start position.

Note:

- ▶ The arrow in Fig. 14A shows a small hole on the top of the water selector cover. This is a ventilation hole that prevents siphonage. A hose that goes to the top of the float tank is connected to the tulle.

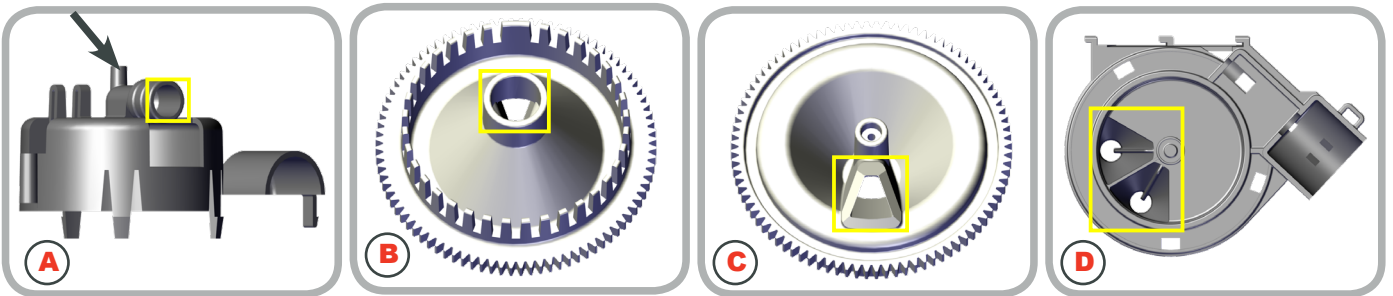

Fig. 14 Water selector components

3.7 Dosing the coffee product

The coffee product is dosed when:

- The float is in the highest position.
- The high temperature sensor measures a temperature that is higher than the blocking temperature.
- Pressing a selection button sets the high pressure pump in motion (Fig. 16) or a specific amount of time.
- The flow meter (Fig. 15) measures the amount of water that is moved.
- The float and the magnetic valve ensure that the correct level of water is maintained in the float tank. The high pressure pump (Fig. 16) is a rotation pump and pumps at a pressure of 9 bar.

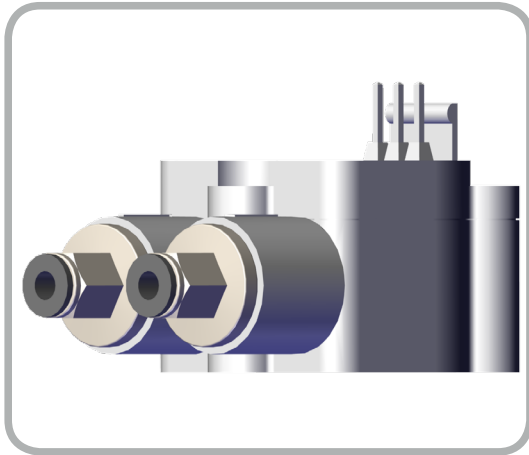

Fig. 15 Flow meter

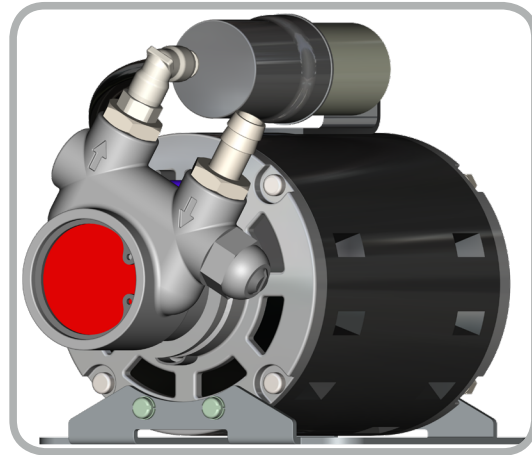

Fig. 16 Rotation pump

The volume of moved liquid (yield) is measured by the flow meter. After the flow meter (Fig. 15) has measured the amount of water, the valve at the top of the boiler will close and switch off the high pressure pump.

The pressure generated by the high pressure pump is displayed on the pressure meter (Fig. 17).

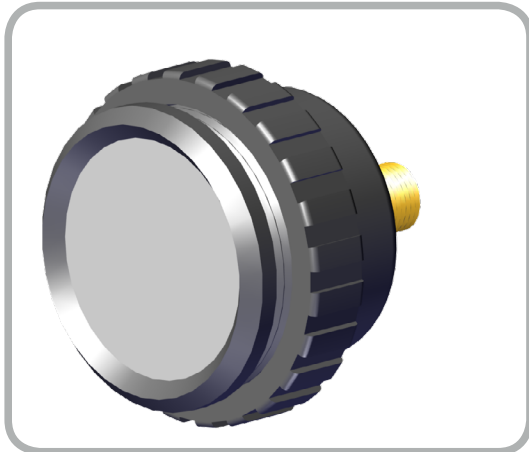

Fig. 17 Manometer

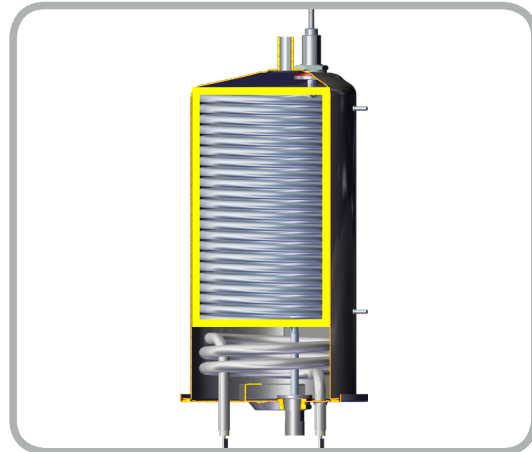

Fig. 18 Boiler incl. heat exchanger

The heat exchanger is in the boiler. Cold water is pumped from the bottom of the boiler through the heat exchanger (Fig. 18) and exits at the top of the boiler.

The heat exchanger has a content of 145 ml; the maximum amount of water dosed for a coffee product in 1 cycle is 225 ml. Because the heat exchanger always contains water and the heat is quickly transferred from the water in the boiler through the heat exchanger to the water for the coffee product and the maximum amount for 1 cycle is 225 ml, the dosed water will always have the correct temperature.

When the high pressure pump is triggered, the valve (Fig.19) on the top of the boiler will open a fraction of a second later. This ensures that the pressure at which the water is pressed through the coffee is always the same.

The hot water flows through a sieve in the brewer (Fig.20) where it is pressed through the coffee cake and flows into the cup.

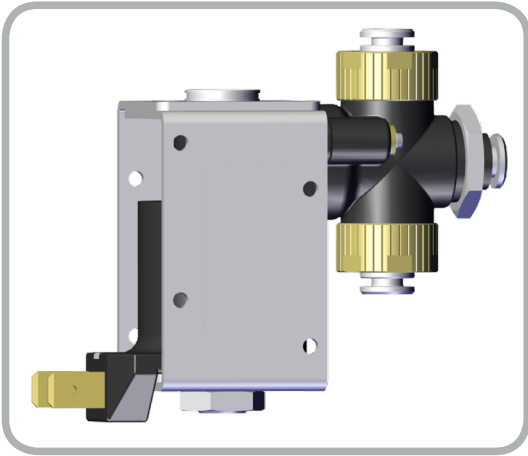

Fig.19 Valve

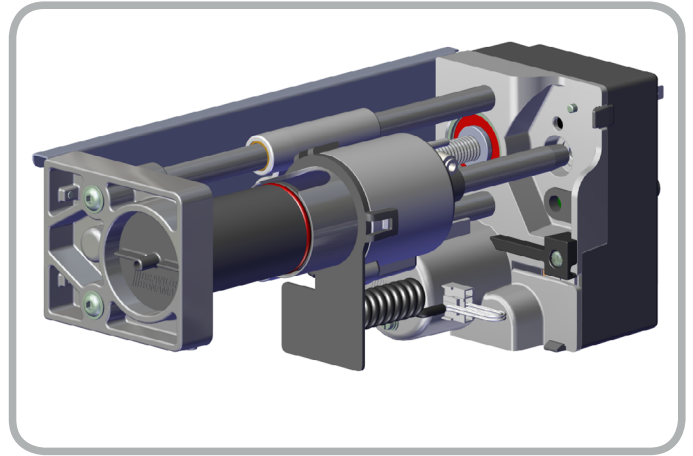

Fig.20 Brewer

4. Powder dosing system

The powder dosing system consists of an ingredient canister that is driven by the canister motor. Pressing the start button starts the canister motor after a certain delay. This motor drives a worm, which transports the ingredient to the canister's outlet. The controls for the canister motor enable the timing and the dosing speed to be controlled independently. This enables ingredients to enter the mixing chamber while the water is flowing.

The canister motor will stop a little sooner than the water in order to rinse the mixing chamber. The amount of time water flows in the mixing chamber before and after a product falls into the mixing chamber can be set. The longer the pre-/post-rinsing lasts the faster the canister motor rotates in order to dose the product faster. The processing time for the drink does not change.

The number of revolutions the motor rotates is measured by an active revolution counter. The canister will use springs based on the type of ingredient. The springs reduce the amount of tunnel formation, meaning the sticking of ingredients to the walls.

5. Mixing system

The mixing unit (Fig.21) mixes the hot water and the ingredient.

When a selection button is pressed, the water is dosed in the mixing chamber after a slight delay. The product falls into the mixing chamber. The mixer starts rotating according to the set speed, which can be changed. As described in the previous chapter, the pre- and post-rinsing times can be set. The longer the pre-rinsing, the lower the chance that product will fall into a dry mixing chamber. The longer the post-rinsing, the less product will remain in the mixing chamber.

There is a exhaust hood on top of the mixing chamber (Fig.22). This cover has an opening at the back that the plates press into an exhaust outlet. This exhaust system ensures that steam from the mixing chamber does not reach the ingredient canister outlet. Fig.23 shows an example of an exhaust system.

The number of revolutions the motor rotates is measured by an active revolution counter.

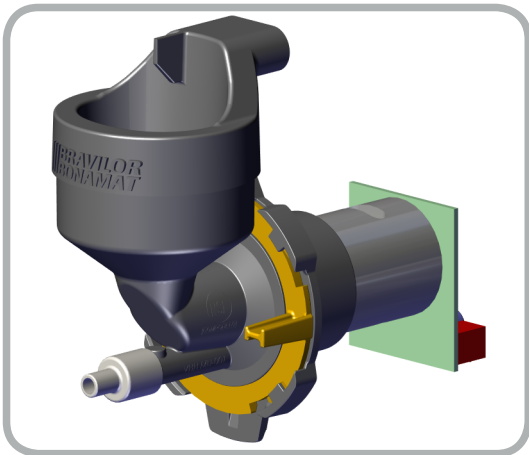

Fig.21 Mixing unit



Fig.22 Exhaust hood

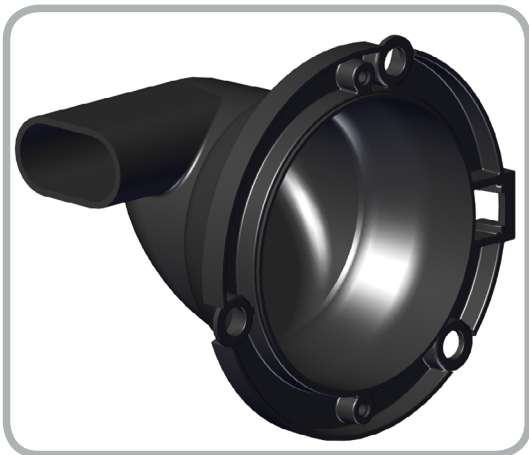

Fig.23 Steam exhaust system for the mixing system

6. Ventilation system

The ventilation system (Fig.24) ensures that the hot steam that is produced during dosing can escape. This prevents the hot steam from settling and condensation from forming in the mixing chamber. This substantially decreases the amount of filth that can settle in the mixing chamber and keeps the canister outlet free from blockage.

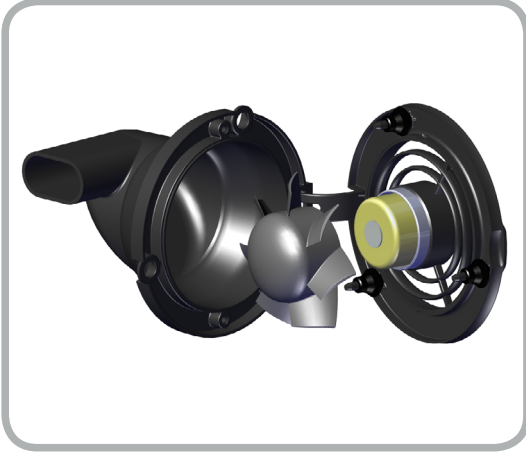

Fig.24 Ventilation system

7. Brewer

7.1 Brewer operation

Coffee falls in the brewer housing.

The coffee is pressed according to a preset pressure. The default pressure is 15 kg. If set, the coffee cake is then wet with a predefined amount of water. Water is then pressed through the filter and the coffee cake at a pressure of 9 bar so the finished product can flow into the cup. The filter ensures that the water is distributed evenly over the coffee cake.

Pressing a selection button that uses ground coffee from the coffee grinder starts the following process:

- Ground coffee falls in the brewer housing. The brewer is in stand-by mode (Fig.25).
- The brewer housing then moves forward to press the coffee (press 1) and create a coffee cake (Fig.26).
- If the machine is set to 'pre-wet', the coffee cake will be pre-treated with water after press 1.
- If set, there will be a 'relax time' after the 'pre-wet'.
- If set, the coffee cake will be pressed a second time (press 2) after the 'relax time'. This press is added to the pressure of press 1.
- If set, a waiting time (pause) will take place after 'press 2'.
- The water will be pressed through the coffee through the filters (in front of and behind the coffee cake). The filters ensure that the water is evenly pressed through the coffee cake (Fig.26).
- After the selected drink has flowed through the outlet into the cup, mug or jug, the brewer housing will slide back and drop the coffee cake in the waste bin (Fig.27 and Fig.28).

The brewer returns to stand-by mode.

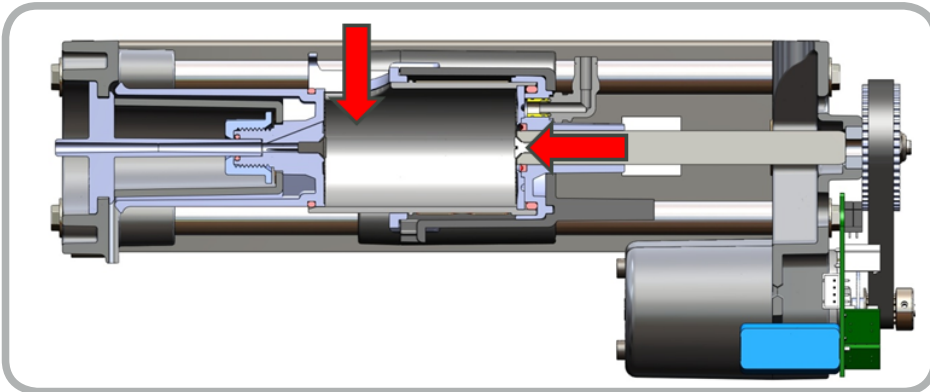

Fig.25 Brewer with a housing in a position that enables coffee to be dosed

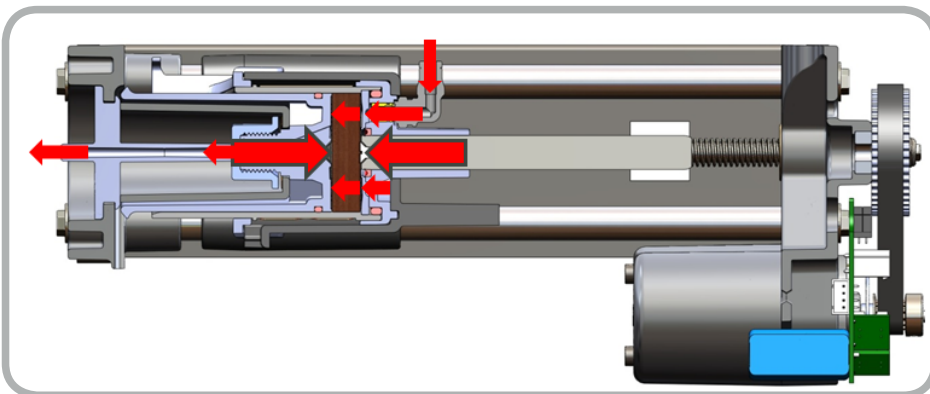

Fig.26 Brewer with coffee cake that is being pressed so water can be dosed

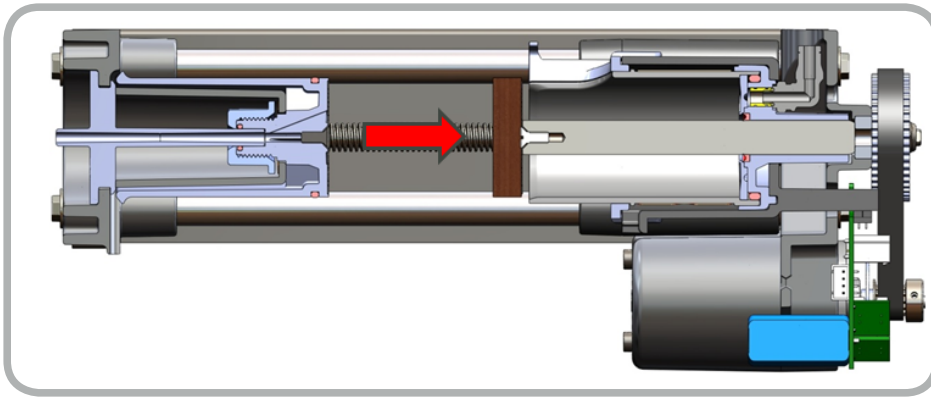

Fig.27 Brewer with retracted housing

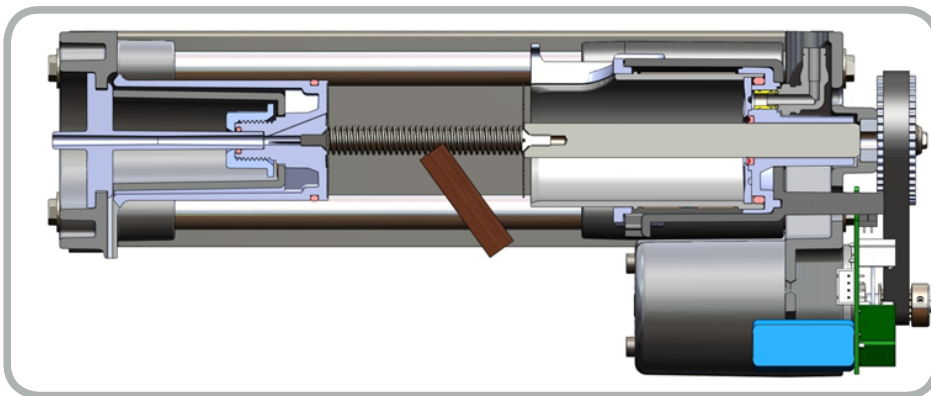

Fig.28 Brewer with entirely retracted housing so the coffee cake falls in the waste bin

The maximum amount of ground coffee the brewer can hold is 20 grams.

The maximum amount of product that is dosed in 1 cycle is 225 ml.

If one of the amounts is higher than indicated above, the machine will make the drink in several brew cycles. If the drink is made in several cycles, the machine will distribute the cycles evenly to ensure that the quality of the cycles is the same.

7.2 Brewer heating

The brewer's cylinder has a heater that ensures that water flowing in does not immediately cool down and re-duce the temperature of the drink. The heater is on by default but can be switched off in the program menu. This temperature is also measured by an NTC (Negative Temperature Coefficient) thermistor.

The temperature depends on a number of factors:

- The ambient temperature where the machine is located.
- How long the heater is on.

8. Coffee grinder

Based on the type of the machine it will have a single or a dual grinder (Fig.29).

If the machine has a dual grinder, one grinder will be for the coffee recipe and the other for the espresso recipe. The coffee grinders may have to be adjusted during installation in order to determine the coarseness of the grind. Because the grind is important to obtaining a good coffee product, the grinder should be adjusted by someone who knows about coffee.

8.1 Calibration

A special key is needed to calibrate the grinder. The key is supplied with the machine.

- Remove the instant canisters to access the grinder's adjustment points.
- Turn the key to the left for a coarser grind.
- Turn the key to the right for a finer grind.

Every time the grinder is adjusted, the coffee must be reweighed and the new amount set in the designated program.

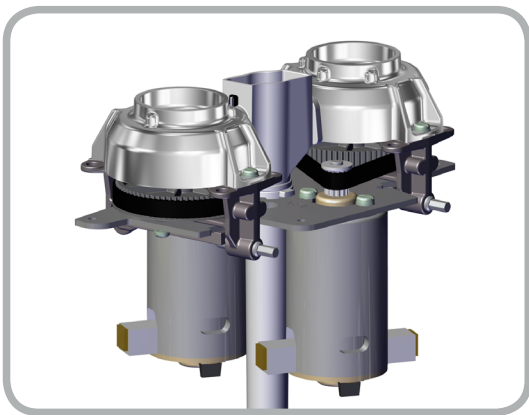

Fig.29 Dual grinder

9. Recipes

9.1 Recipe settings

A good coffee drink can only be made if the machine is properly adjusted. A number of the machine's settings can be changed (Fig.30).

Press 'i' on the LCD to display information about these settings (Fig.31).



Fig.30 Recipe screen

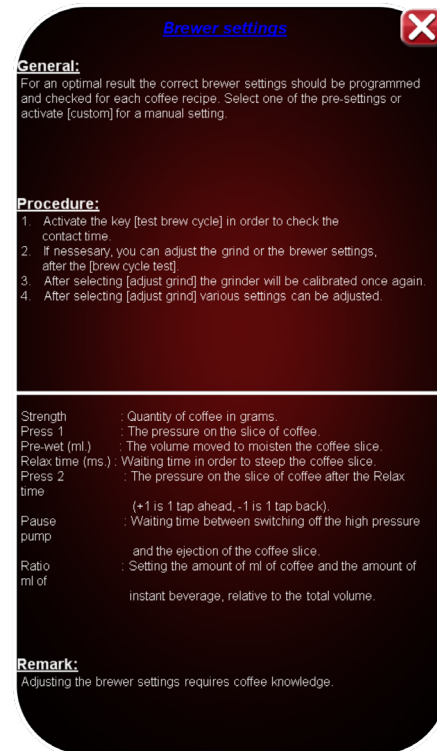

Fig.31 Info screen

- Strength: the amount of coffee used for the drink.
- Pre-settings: Settings that are programmed in the machine + 1 setting that can be freely programmed.
- Press 1: The pressure on the coffee cake: 0 is for a pressure of 15 kg.
- Pre-wet (ml): The amount of water used to humidify the coffee cake.
- Relax time (ms): Waiting time to let the coffee steep.
- Press 2: The pressure on the coffee cake after the relax time (+1 is 1 notch higher than the pressure of Press 1, -1 is 1 notch less than the pressure of Press 1).
- Pause: Waiting time after Press 2 and before the high pressure pump is activated.
- Test Brew cycle: The settings are checked by making a drink.
- Adjust grind: This is where you can check whether the grind is good and weigh it if necessary.

Note:

- ▶ *The coarseness of the ground coffee determines how good a coffee drink is, which is why it's important that the grinder is well adjusted.*
- ▶ *Always use the designated program to adjust the coarseness of the grind because it ensures that the right amount of coffee is weighed.*

10. Operating system

The operating system consists of a:

- Touch screen incl. circuit board and operating system
- Control board

10.1 Touch screen including control board

The circuit board with the operating system is in the touch screen display.

Settings that can be changed in the program menu are also saved in the Eeprom of this circuit board. Replacing the touch screen returns the machine to its factory settings. It is possible to save the settings on an SD card so they can be uploaded to the new touch screen display.

10.2 Control board

The control board is in the machine and contains the electronics that drive the machine. This board controls the power for the low-voltage components and the temperature. The board also contains one or more relays and semiconductors that switch the electrical components on and off. It also has a microprocessor that controls the boiler routine.

10.3 Bus system

The machine has a bus system (Fig.32).

In contrast to conventional systems where each of the components is wired to the circuit board, the wiring in the bus system runs from component to component and back to the circuit board (Fig.32).

A signal sent by the control board passes through each of the components but is only recognized by the component it is intended for. The signal then returns to the control board with the confirmation that the command has been executed.

If the component does not execute the command, the control board receives a signal and displays an error message.

This enables very accurate error message to be displayed.

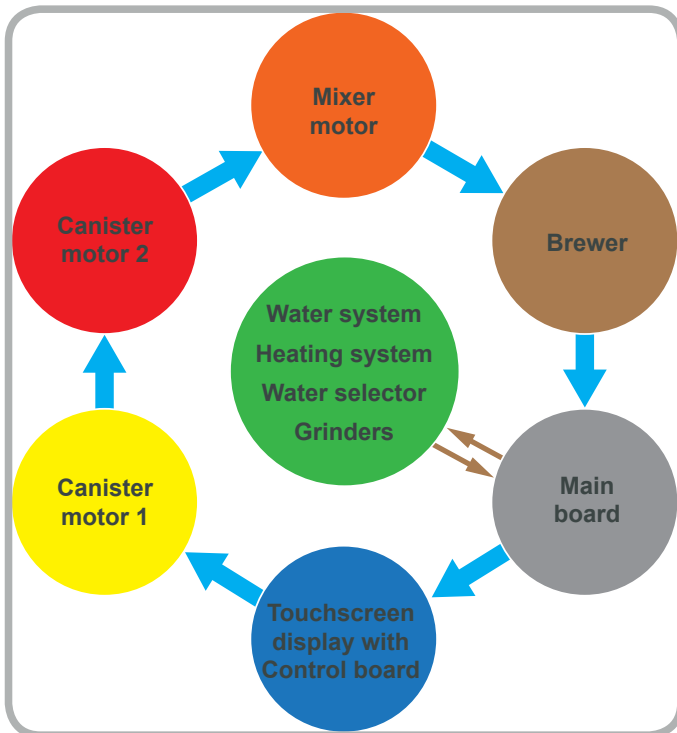

Fig.32 Bus system diagram

11. Hardware protection

The machine has a number of hardware protections.

These protections prevent dangerous situations from occurring, such as overheating and/or water in the machine.

11.1 Overflow protection

This protection is in the float tank and ensures that excess water caused by a too high water level flows to the bottom of the machine through the overflow and hose.

11.2 Return flow protection

A pipe in the float tank sprays the water from the magnetic valve against the cover of the float tank. The wa-ter then flows into the float tank. This prevents water from flowing back into the system and entering the wa-ter supply if the water pressure on the magnetic valve drops.

11.3 High temperature safety switch

The high temperature safety switch is fastened to the outside of the boiler with two Klixons.

If, for whatever reason, the controls do not switch off the boiler, the Klixons will ensure that the voltage on the element is mechanically switched off. Steam escapes from the boiler during the boil-dry process. This steam enters the water selector and exits between the cover and the distributor. To prevent droplets from entering the machine, the water selector is equipped with a drip tray (Fig.33).

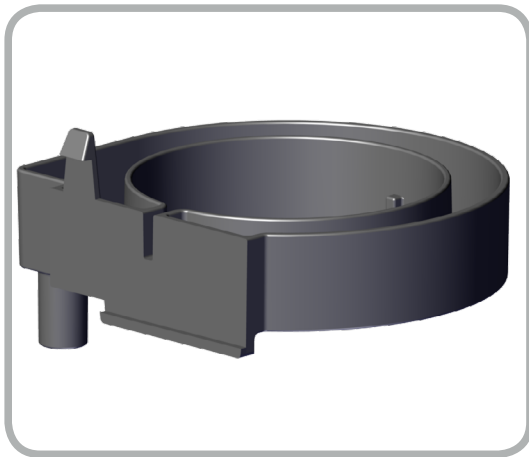

Fig.33 Drip tray for the water selector

11.4 Waste bin (brewer) protection

The protection is triggered by a switch that is activated by the waste bin.

To prevent dangerous situations from occurring when the brewer is moving, a built-in protection prevents the machine from being used when the waste bin is removed.

11.5 Grinder protection

The protection is triggered by a switch that is activated by the bean canister.

To prevent dangerous situations from occurring with the coffee grinder, a built-in protection prevents the ma-chine from being used when the bean canister is removed.

12. Software protection

The machine is equipped with software protection; the software monitors all the input and output of the machine throughout the whole process. If situations occur that are not allowed, the software intervenes. As a result, the machine switches off and an error message appears on the display.

The error message can be reset by turning the machine off and on. If the error message keeps coming back, further investigation need to be done to solve the problem. To solve the problem, it should be noted that error messages may have different causes. This means that the cause of the problem can be a defective component. But, it can also be caused by the location (where the machine is situated).

For possible solutions to these error messages, see the error list below.

00000 Communication error bus system:

- Occurs when the bus systems circuit is interrupted.

00001 Canister motor runs insufficiently:

- Light sensor receives not enough pulses for too long a time.

00101 Mixer motor runs insufficiently:

- Light sensor receives not enough pulses for too long a time.

00201 Low pressure pump runs insufficiently:

- Light sensor receives not enough pulses for too long a time.

00401 Grinder runs insufficiently:

- The coffee grinders have not received pulses from the hall sensor for too long a time.

00402 Grinder is incorrectly controlled:

- If a semiconductor on the mainboard gets defect the grinder runs unjustified.

02001 Filling process takes too long:

- If the water inlet valve was open for 20 seconds in succession and the float did not rise.

02002 Fill up 3 times without selection:

- Occurs when the magnetic inlet valve is opened 3 times within a short period and no drink has been selected, this indicates that there is a leak in the water system.

02101 Break temperature sensor boiler:

- Occurs when an NTC measures a resistance that is higher than normal.

02102 Short-circuit temperature sensor boiler:

- Occurs when an NTC measures a resistance that is lower than normal.

02104 Communication error boiler:

- The boiler has not been receiving messages for too long.

02201 No pulse detection water selector sensor:

- Light sensor receives not enough pulses for too long a time.

02202 Water selector in wrong position:

- The hot water selector cannot find its zero position.

04101 Communication error brewer:

- The espresso brewer has not been receiving messages for too long.

04102 Break temperature sensor brewer:

- The NTC is measuring an unrealistic resistance.

04103 Short-circuit temperature sensor brewer:

- The heating element is using too many power.

04104 Brewer does not move:

- The espresso brewer mechanism is not reaching the desired position or one of the light sensors is not receiving any pulses.

04201 Water meter gives no pulses:

- Pulses from the flow meter have not been measured for too long a time, this can also be caused if the high pressure pump is not running.

10001 General I/O error:

- The I/O module is reporting an error.

13. The Esprecious program

The Esprecious program consists of a number of basic components with sub functions that can also have sub functions (Fig.34).

Pressing the program button activates the program and enables you to activate or change settings.

Pressing ► to continue to the next screen saves the settings.

In many screens, pressing ⓘ displays more information about the screen's functions.

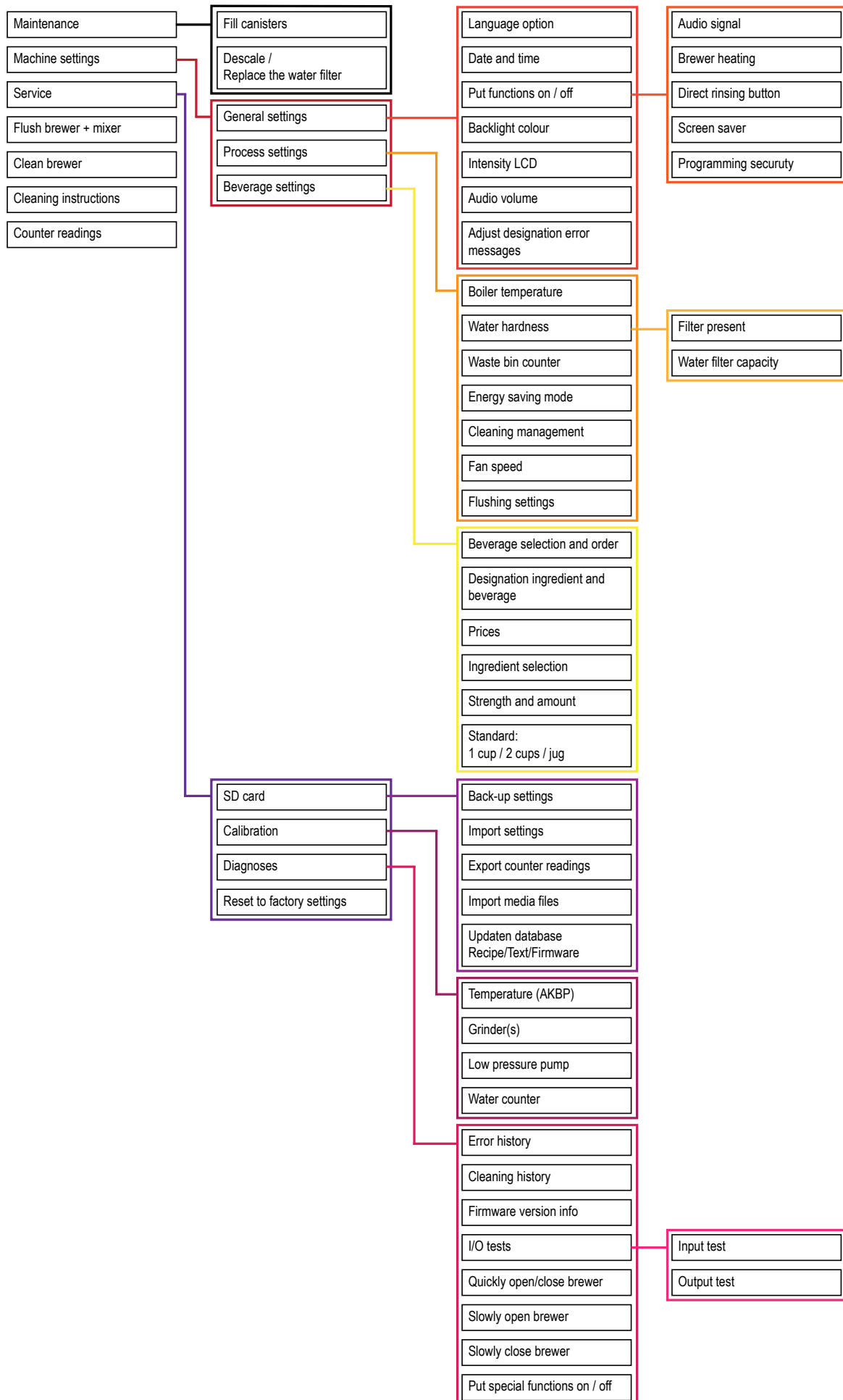

Fig.34 Programming map

